

FRONT VIEW

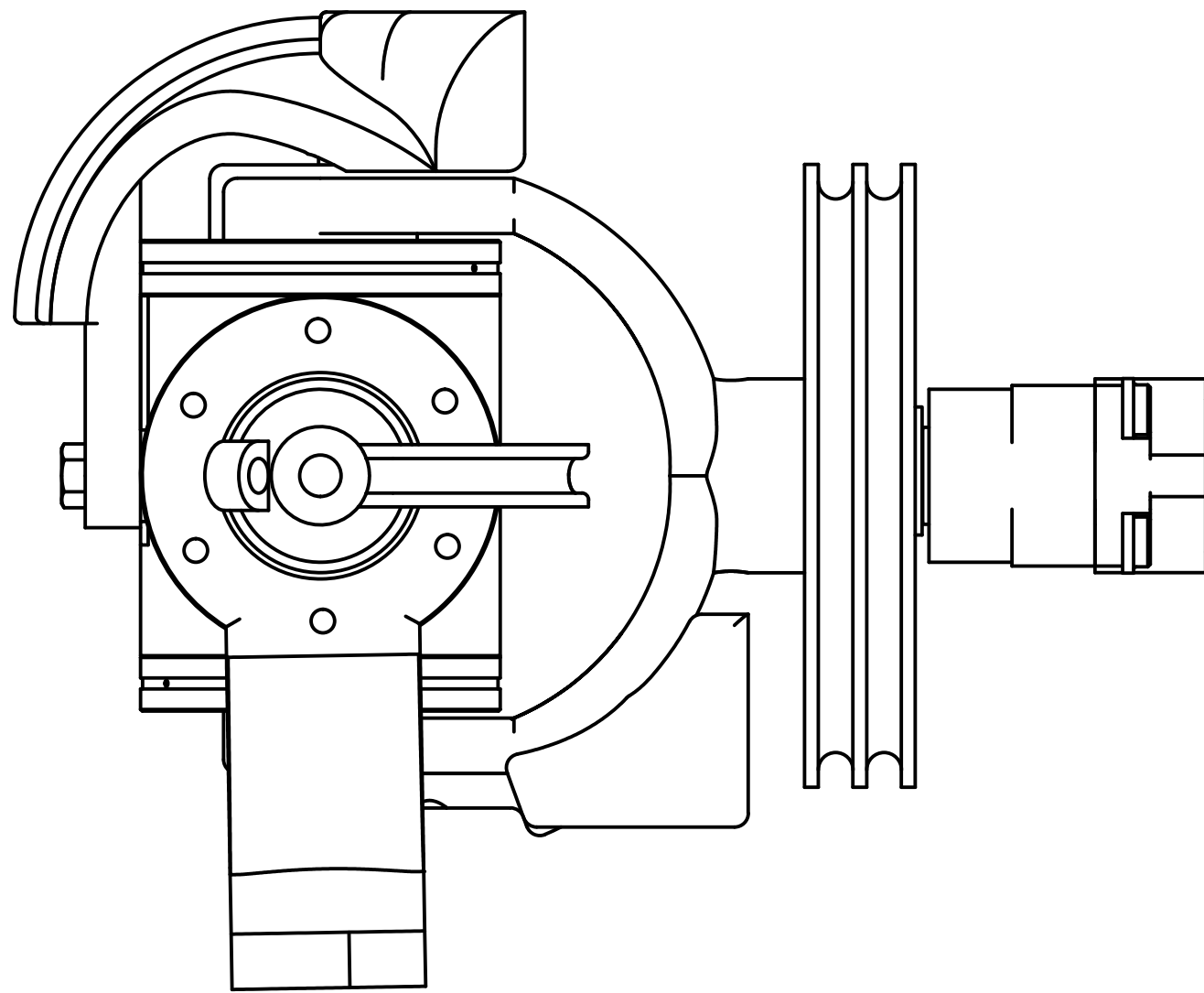

SIDE VIEW

Dept.	Technical reference	Created by <b>TeleX Robotics</b> 12/26/19	Approved by
		Document type	Document status
		Title <b>3-DOF Joint</b>	DWG No.
		Rev.	Date of issue
		Sheet <b>1/9</b>	

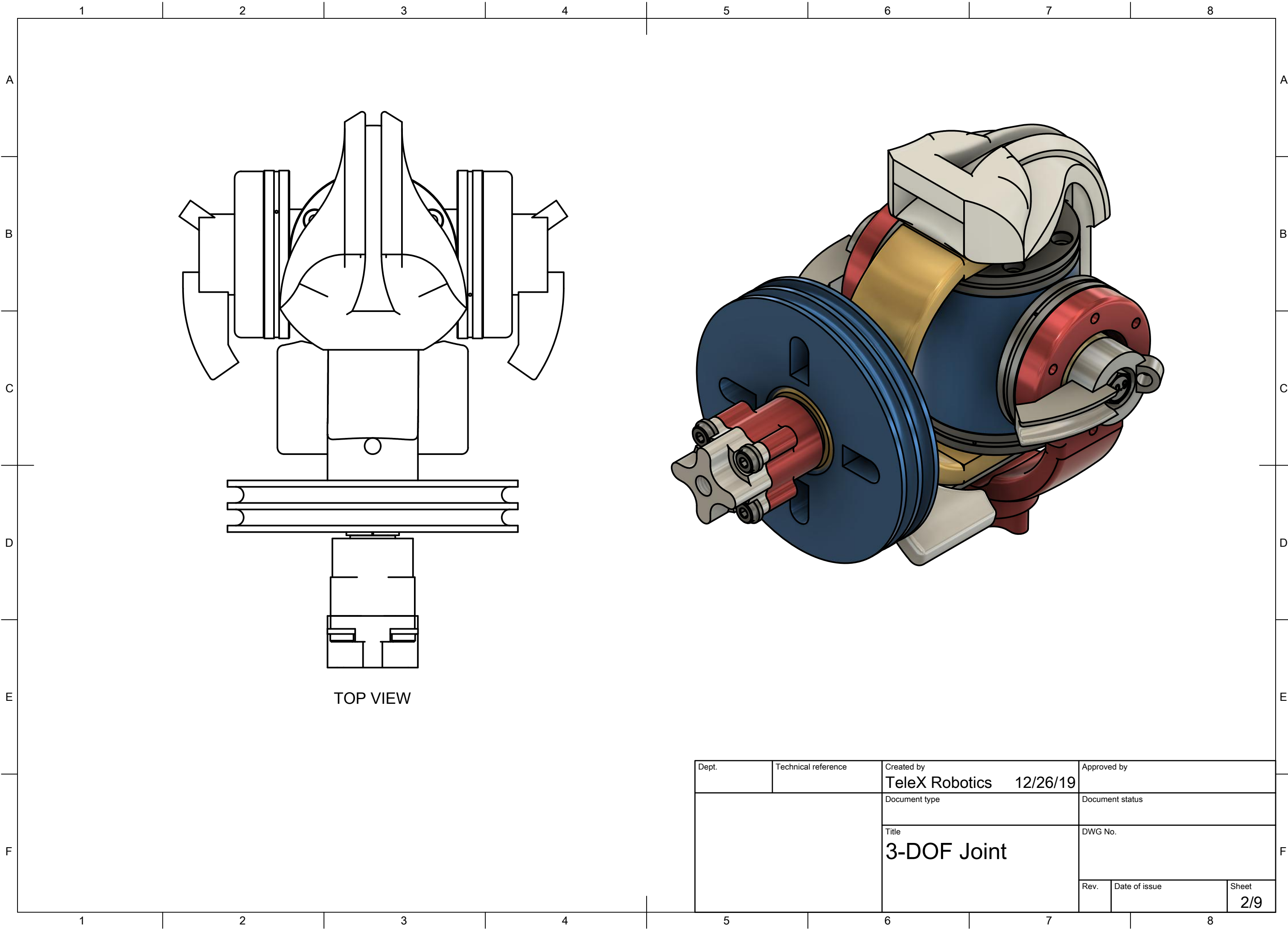

TOP VIEW

Dept.	Technical reference	Created by <b>TeleX Robotics</b> 12/26/19	Approved by
		Document type	Document status
		Title <b>3-DOF Joint</b>	DWG No.
		Rev.	Date of issue
			Sheet <b>2/9</b>

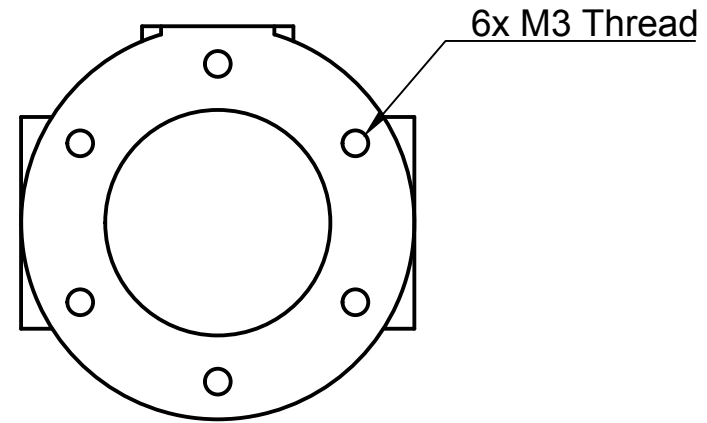
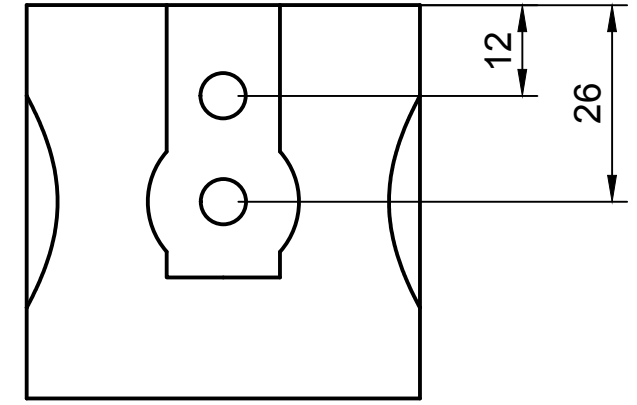
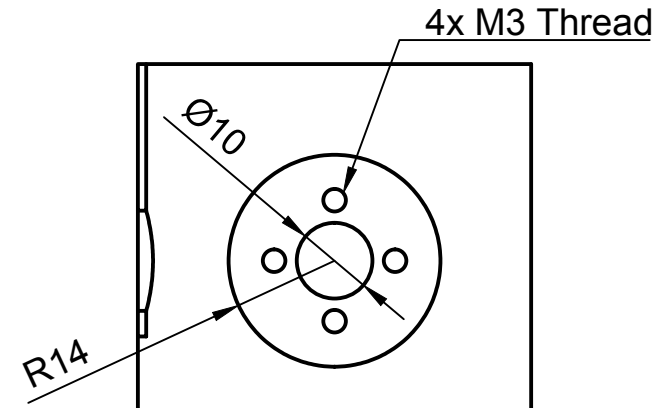
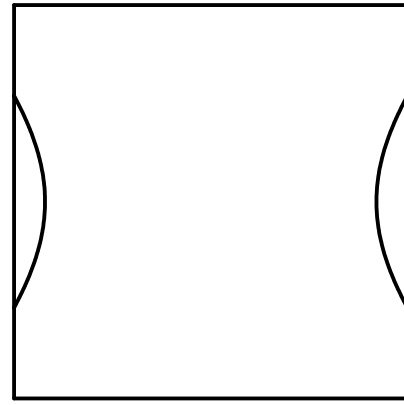
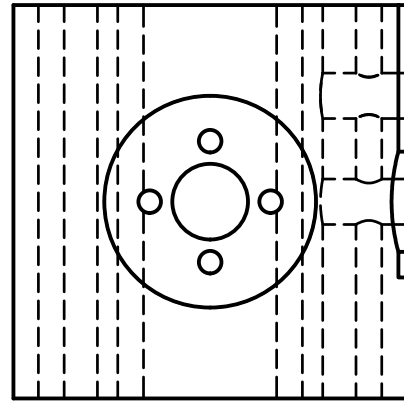
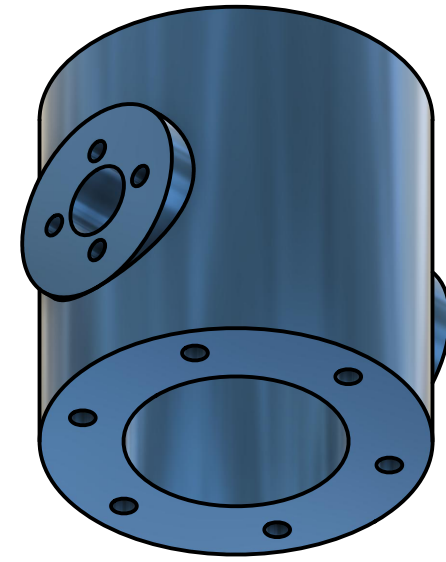
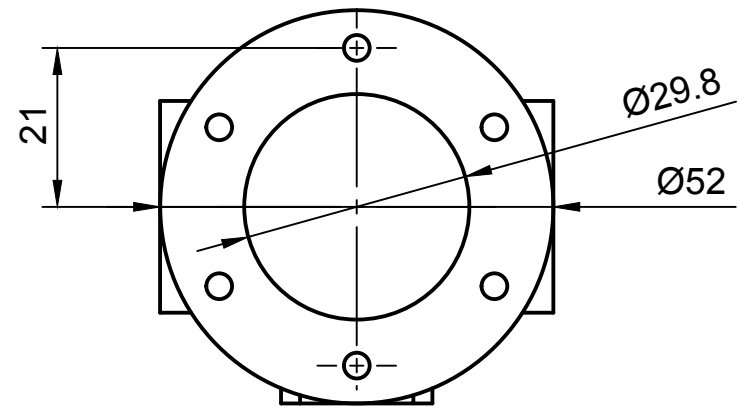

**COMPONENT 6**

Dept.	Technical reference	Created by <b>TeleX Robotics 12/26/19</b>	Approved by
		Document type	Document status
		Title <b>3-DOF Joint</b>	DWG No.
Rev.	Date of issue	Sheet <b>3/9</b>	

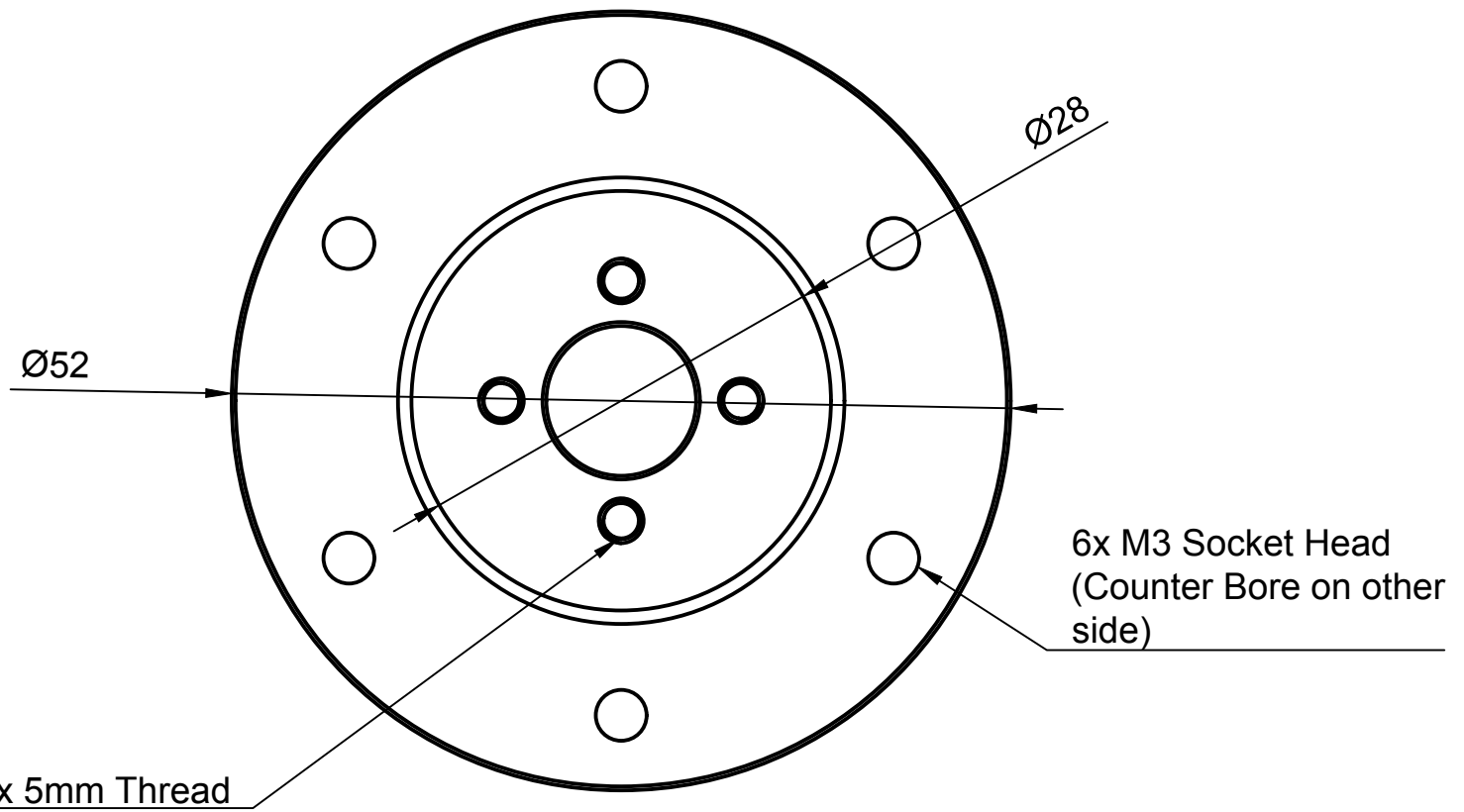
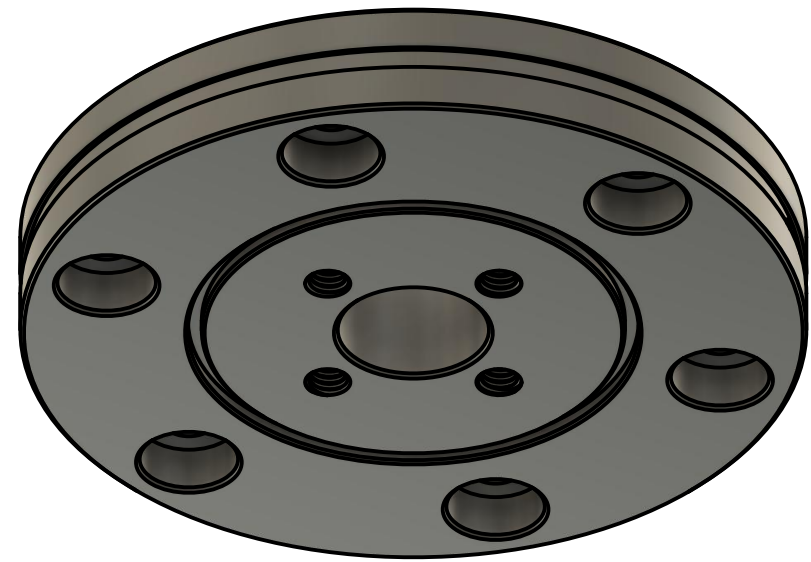
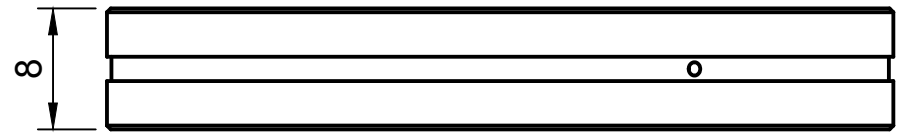
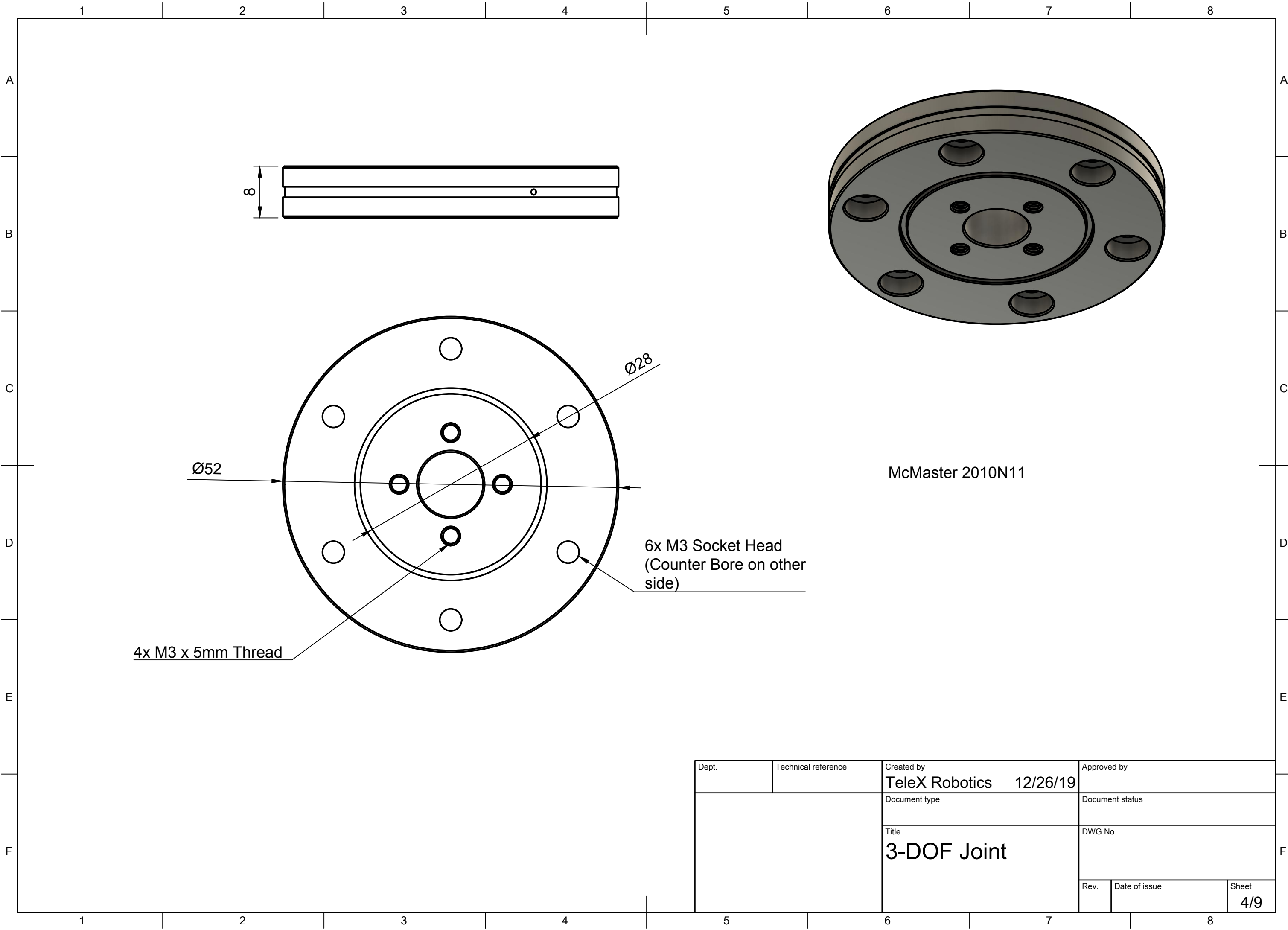

McMaster 2010N11

Dept.	Technical reference	Created by <b>TeleX Robotics</b> 12/26/19	Approved by
		Document type	Document status
		Title <b>3-DOF Joint</b>	DWG No.
	Rev.	Date of issue	Sheet <b>4/9</b>

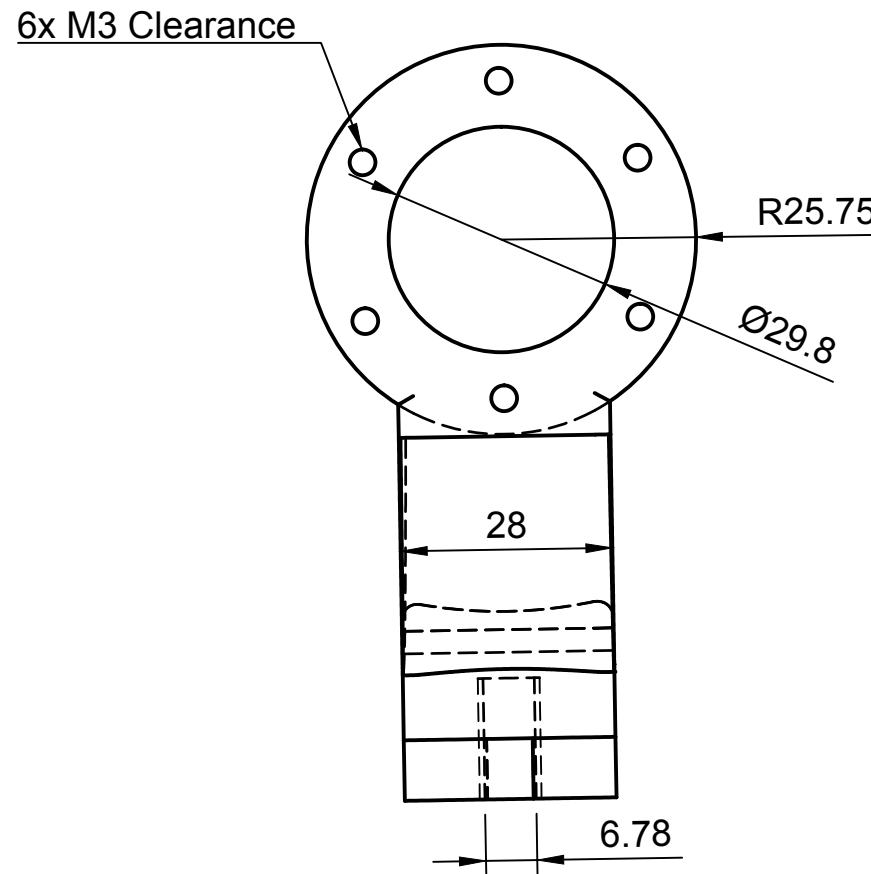
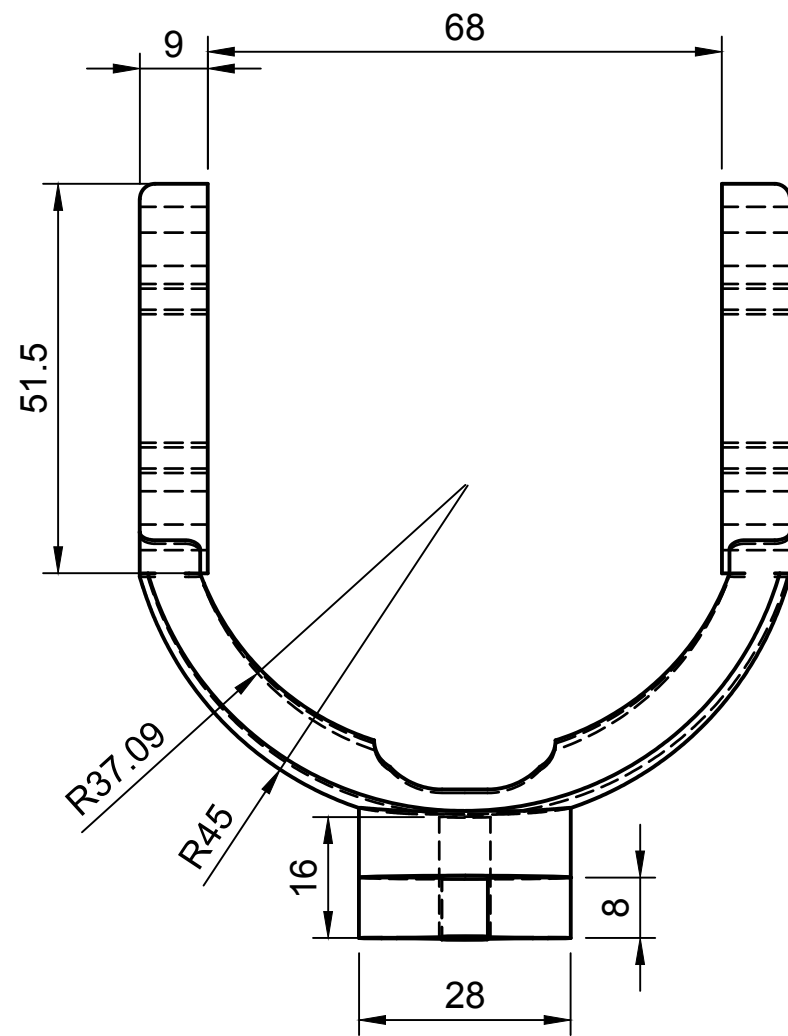
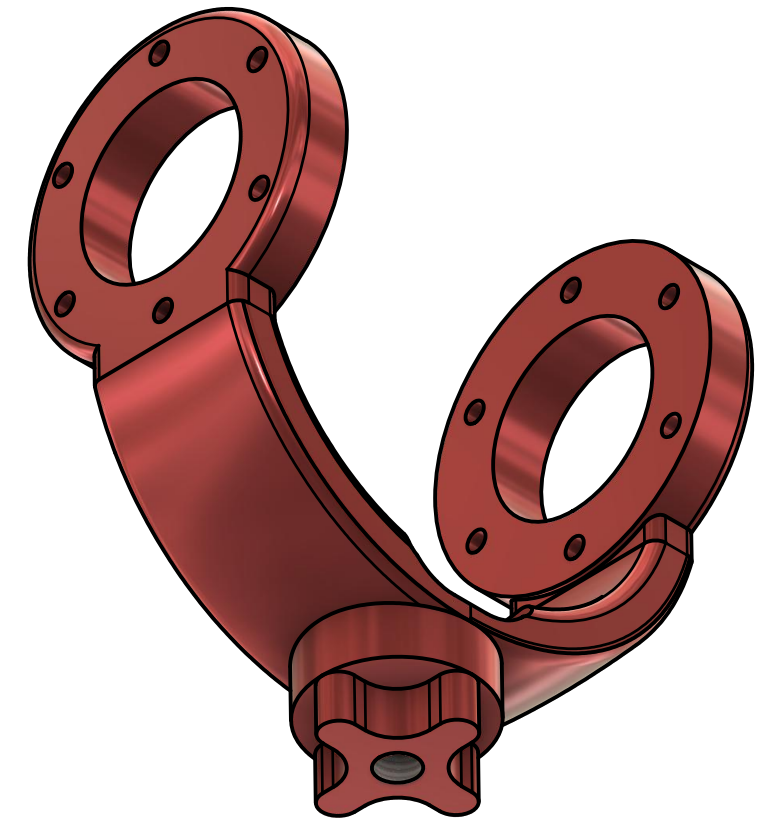
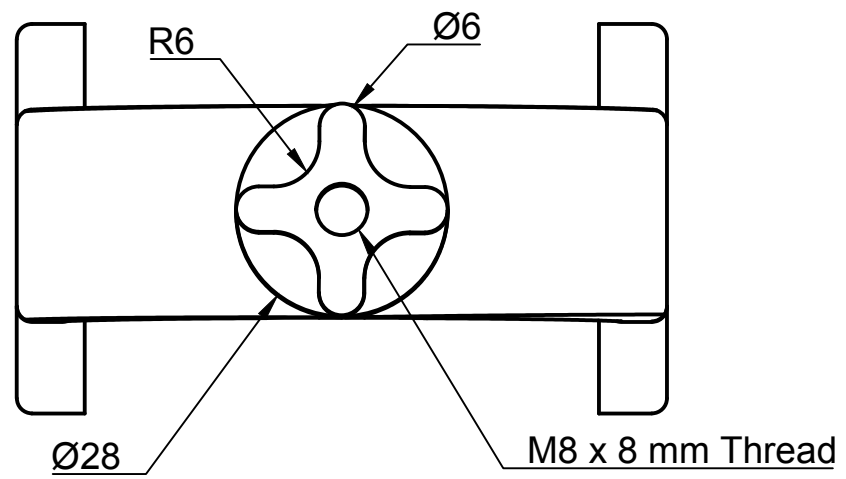

**COMPONENT 7**

Dept.	Technical reference	Created by <b>TeleX Robotics</b> 12/26/19	Approved by
		Document type	Document status
		Title <b>3-DOF Joint</b>	DWG No.
		Rev.	Date of issue
			Sheet <b>5/9</b>

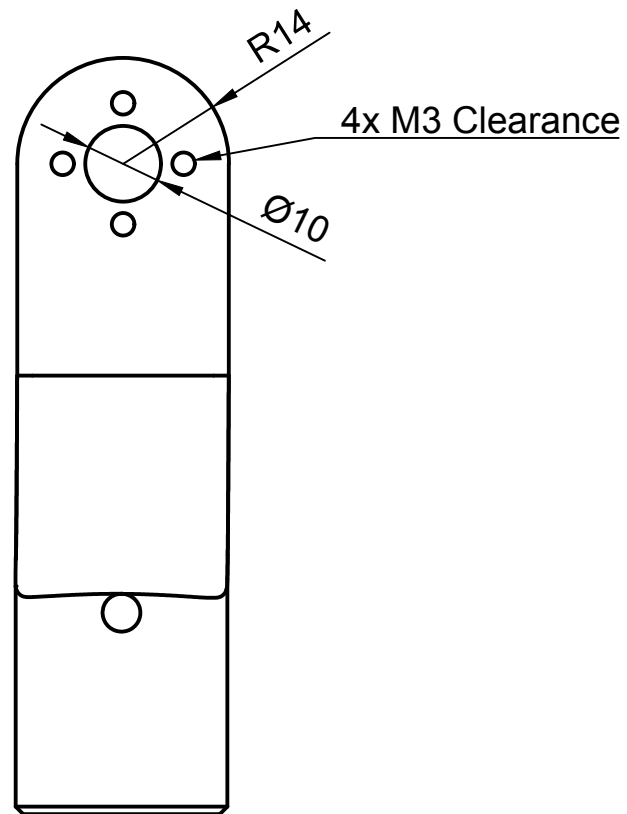
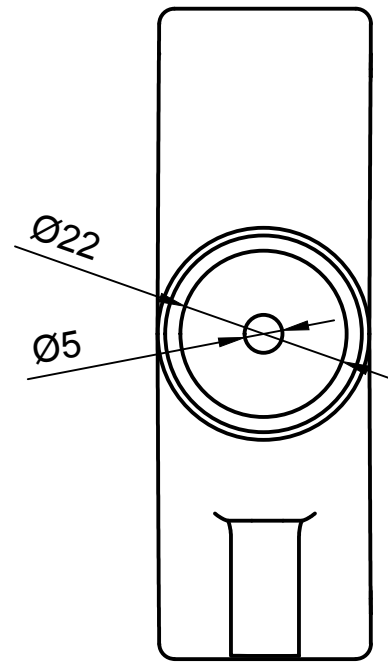
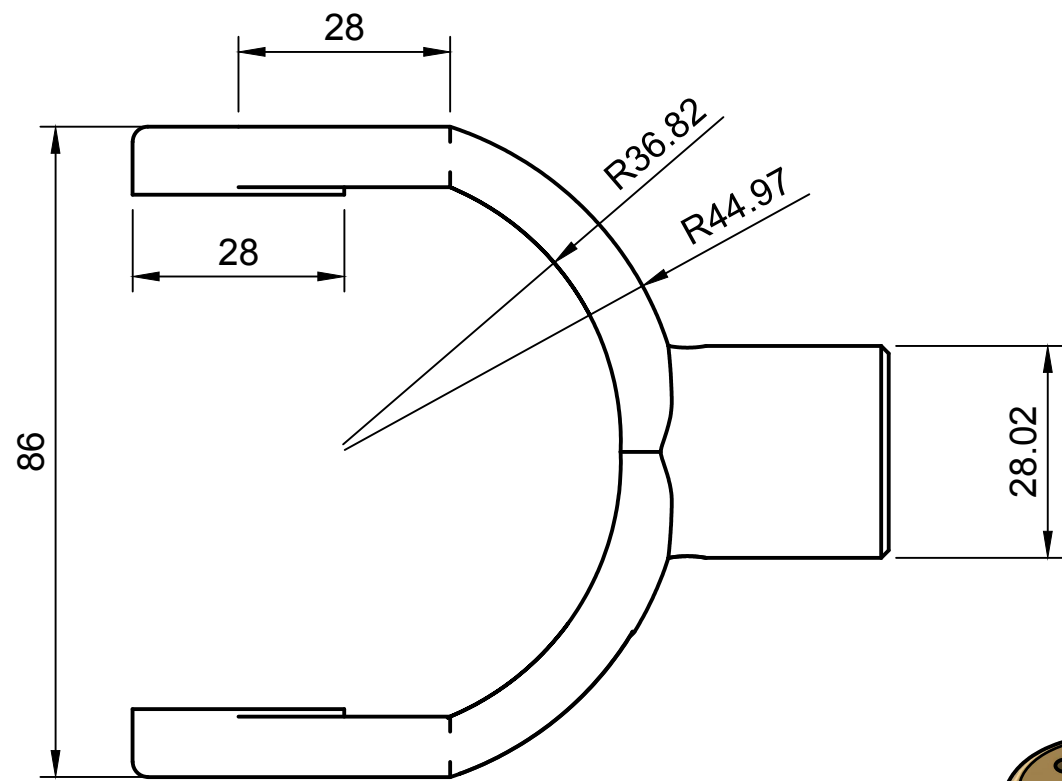

**COMPONENT 10**

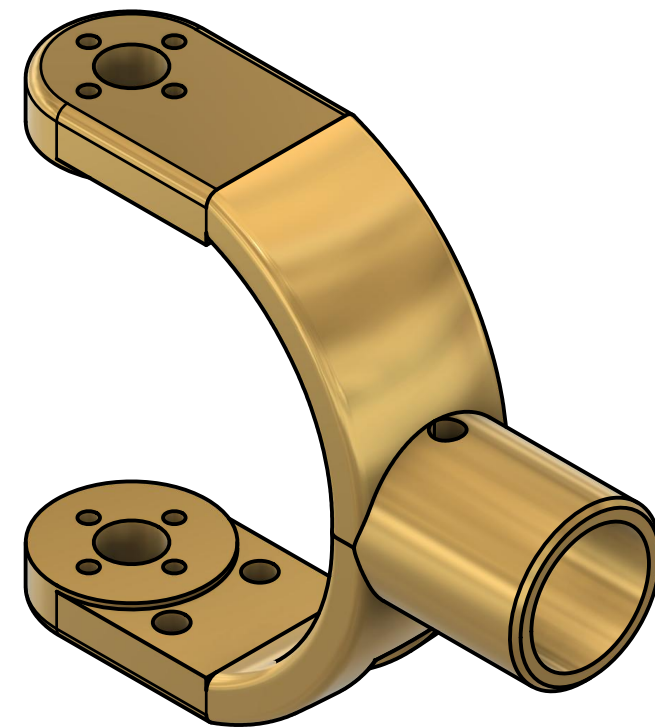

Dept.	Technical reference	Created by TeleX Robotics 12/26/19	Approved by
		Document type	Document status
		Title <b>3-DOF Joint</b>	DWG No.
		Rev.	Date of issue
			Sheet <b>6/9</b>

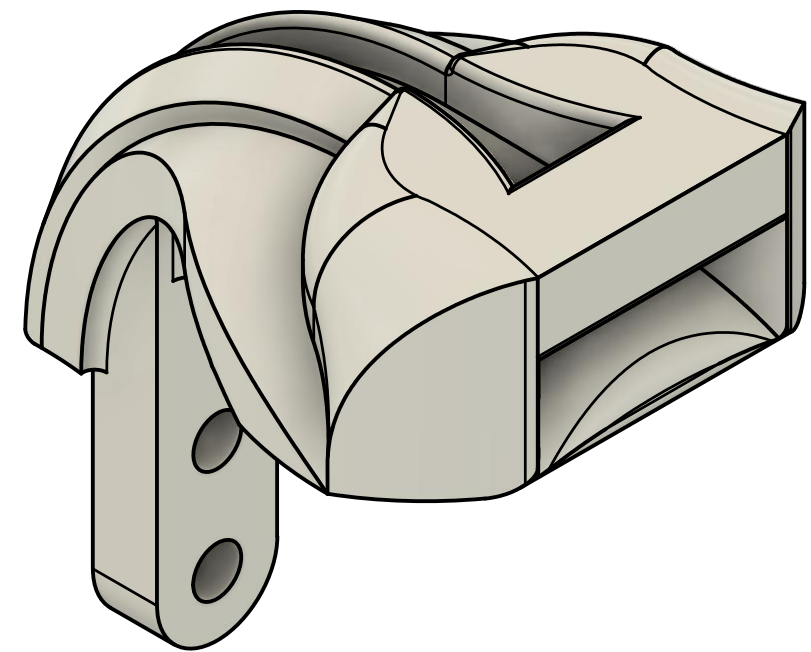
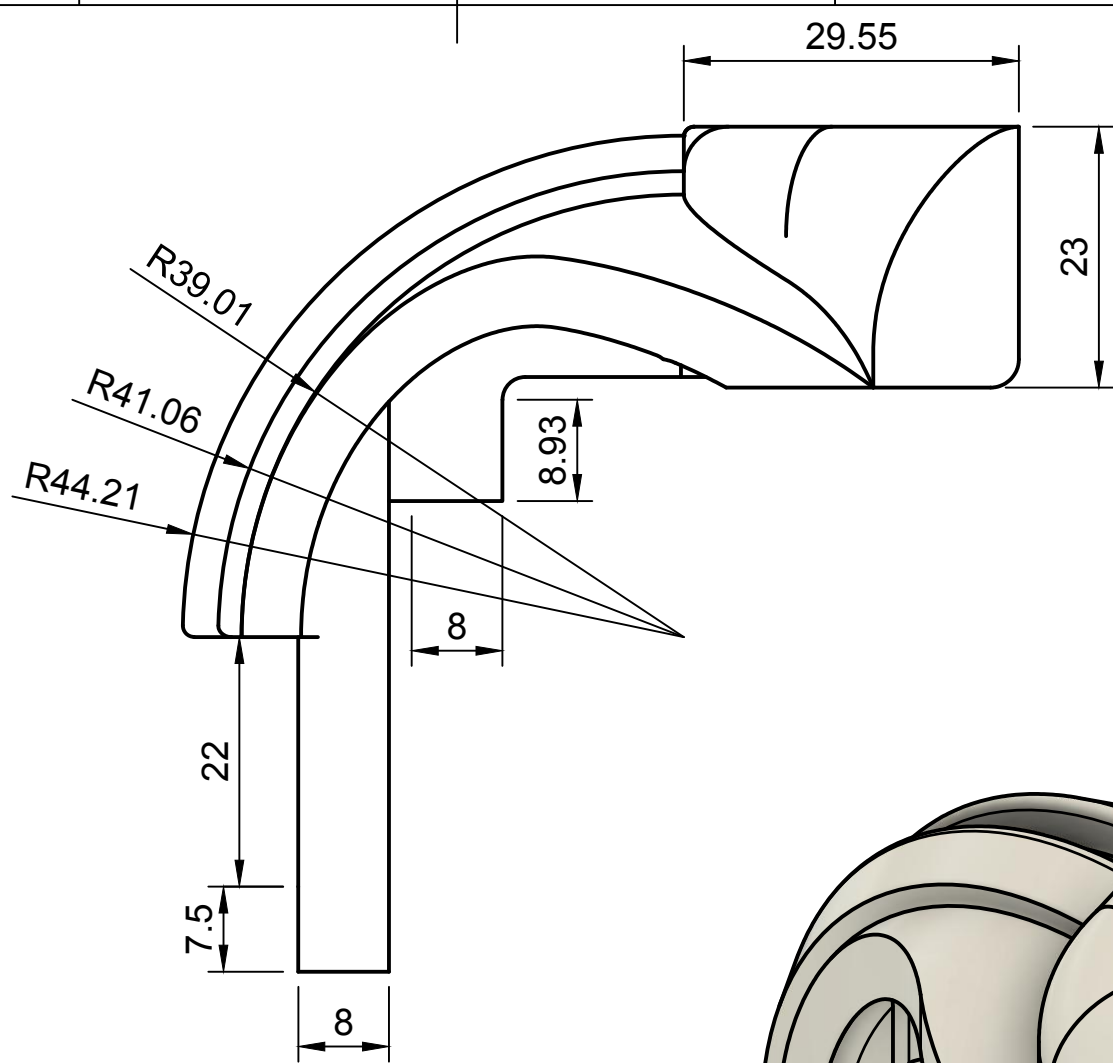
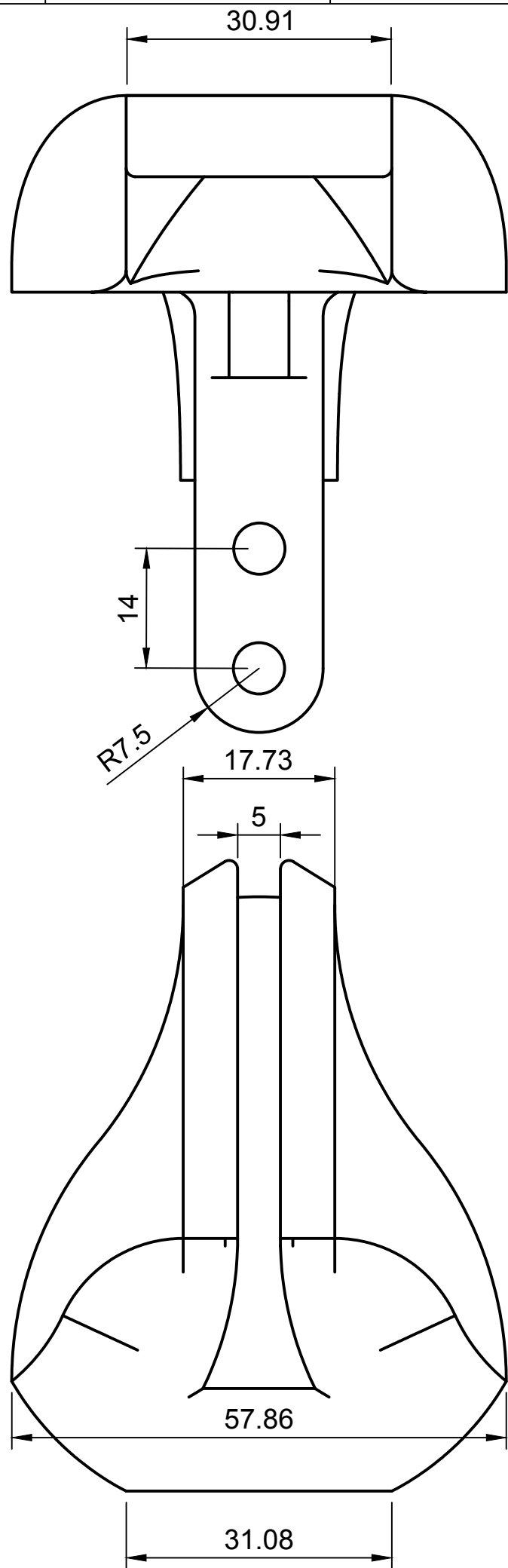

**COMPONENT 25**

Dept.	Technical reference	Created by <b>TeleX Robotics 12/26/19</b>	Approved by
		Document type	Document status
		Title <b>3-DOF Joint</b>	DWG No.
Rev.	Date of issue	Sheet <b>7/9</b>	

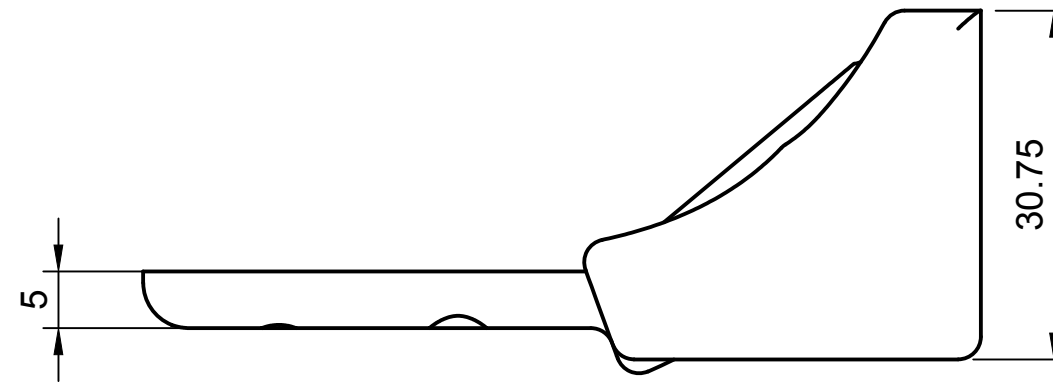
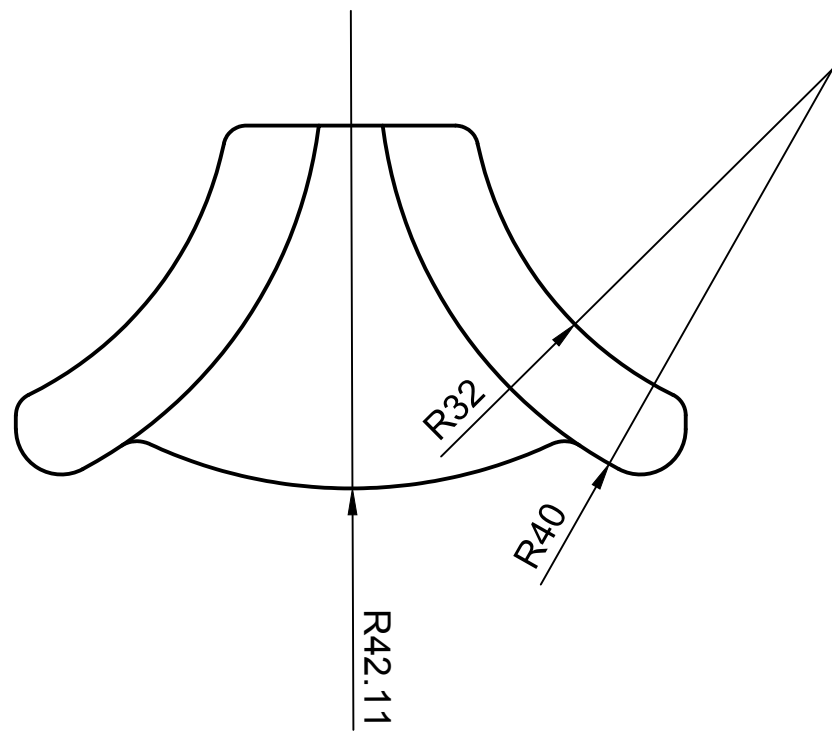

**COMPONENT 59**

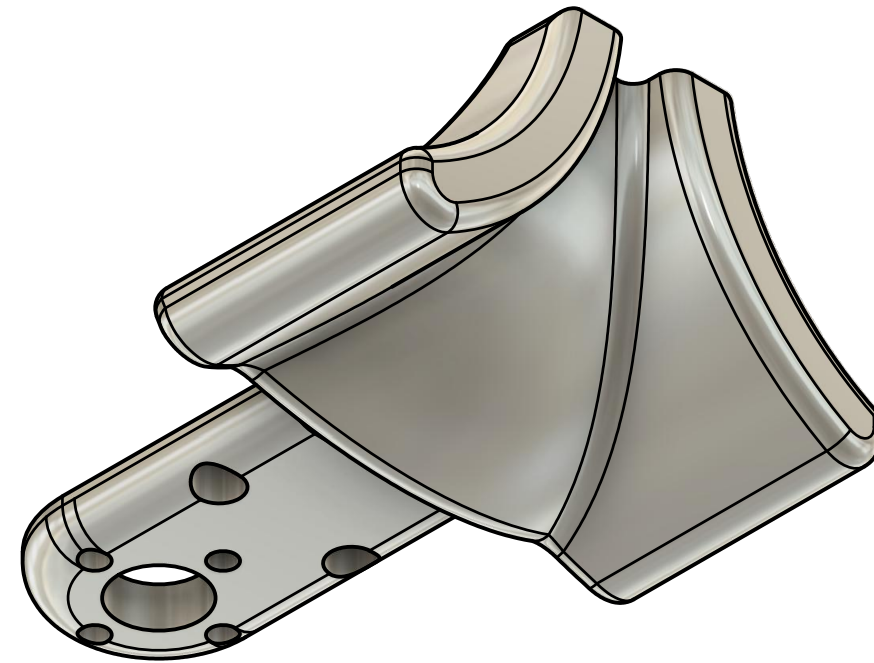
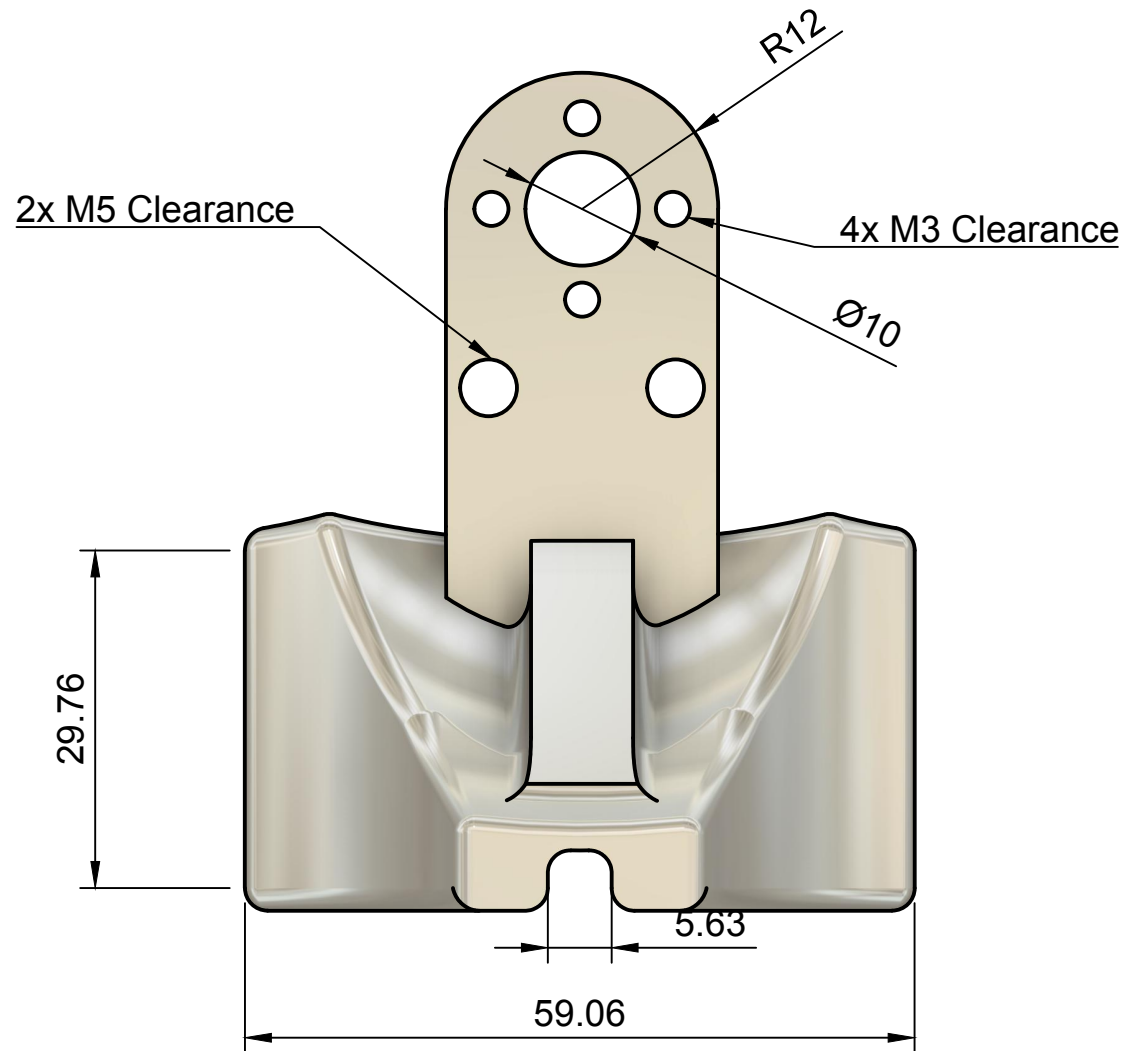

Dept.	Technical reference	Created by <b>TeleX Robotics 12/26/19</b>	Approved by
		Document type	Document status
		Title <b>3-DOF Joint</b>	DWG No.
Rev.	Date of issue	Sheet <b>8/9</b>	



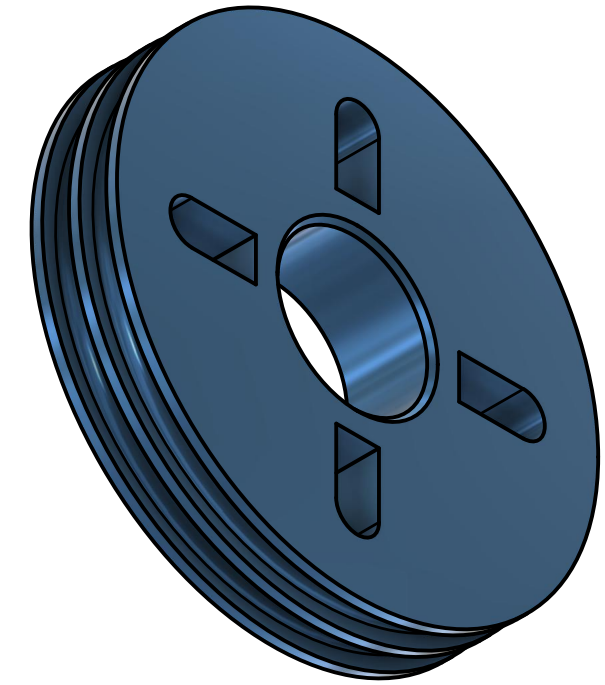
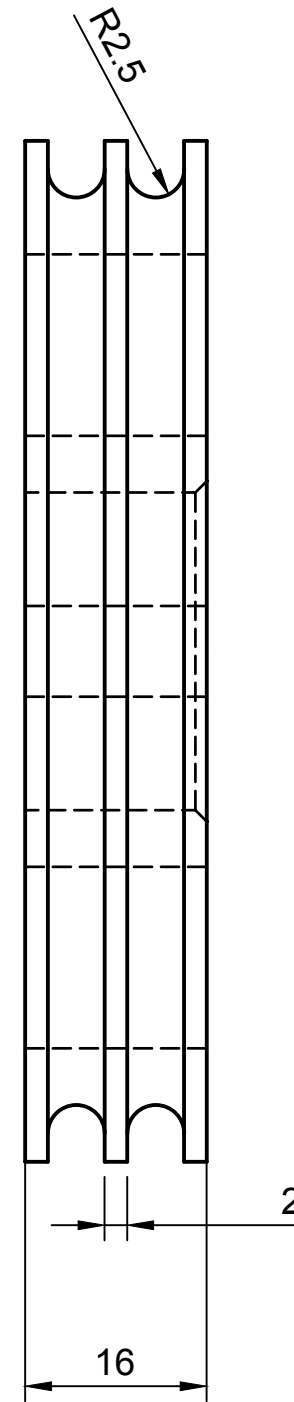
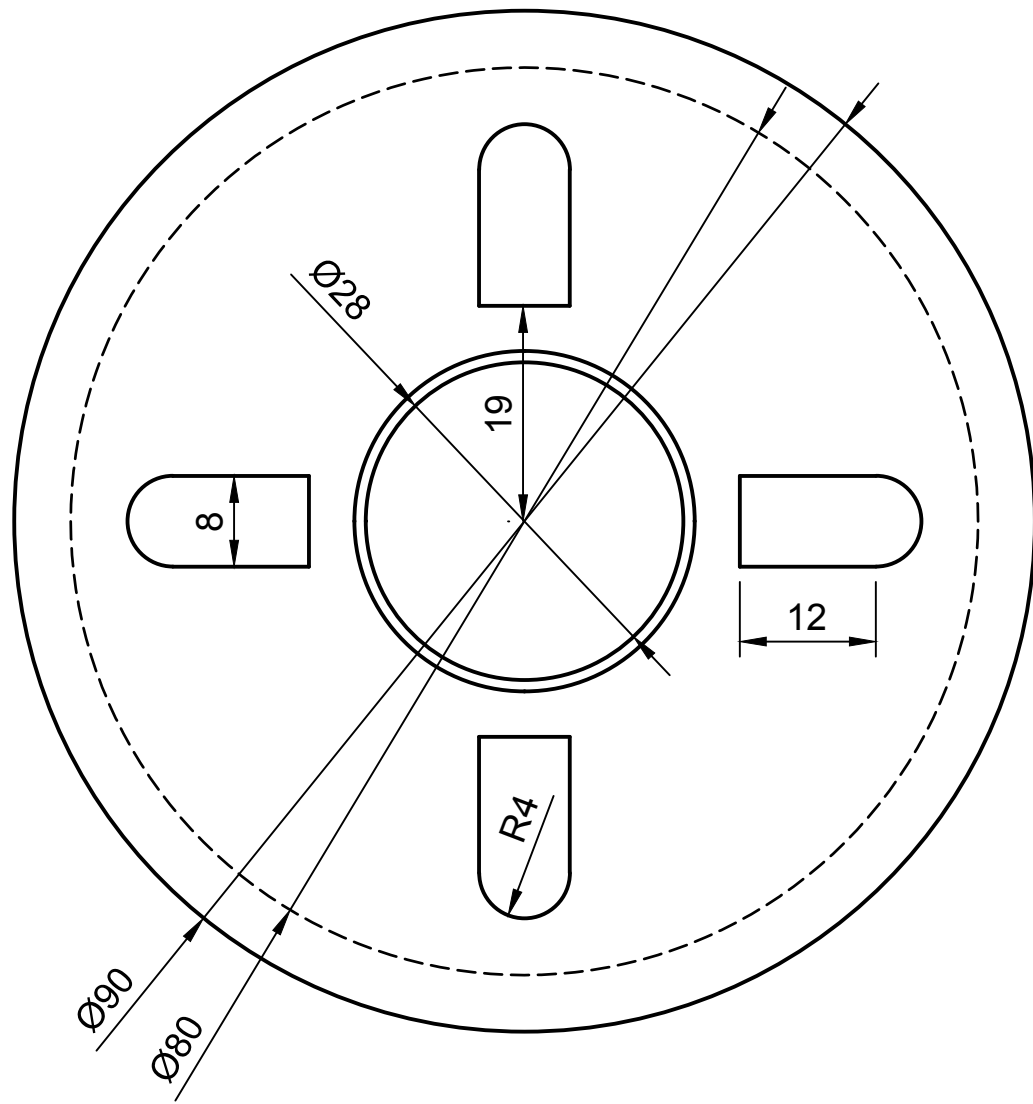

**COMPONENT 37**

Dept.	Technical reference	Created by <b>TeleX Robotics 12/26/19</b>	Approved by
		Document type	Document status
		Title <b>3-DOF Joint</b>	DWG No.
		Rev.	Date of issue
		Sheet <b>9/9</b>	